



BAGNO

CATALOGO GENERALE

 Monlegrappa®



Monlegrappa[®]



BAGNO

SPACE
pag 4

1

OPLA
pag 14

2

GIADA
pag 18

3

MOBILAVA
pag 28

4

STEND-ART
pag 30

5

SYNTHESIS
pag 34

6

SINERGY
pag 60

7

SPACE

Montegrappa®

Space, le sue qualità?
Trasparenti come l'acqua.
Space è una linea di mobili da bagno utili e funzionali che si prestano ad essere inseriti in qualsiasi contesto.
Space propone diverse soluzioni personalizzabili per rendere il vostro locale unico ed accogliente in sintonia con le vostre esigenze.

Space, its qualities?
As clear as water.
Space is a line of useful and functional bathroom furniture suitable to any space. It offers different solutions that you can personalize to make your bathroom incomparable and in accordance with your needs.

Space, und seine Qualitäten? Offensichtlich.
Space ist eine Serie von nützlichen und funktionellen Badmöbeln, die sich in jede Umgebung einfügen.
Space umfasst mehrere auch kundenspezifisch gestaltbare Lösungen, die Ihr Bad zu einem einzigartigen und gemütlichen Raum in Einklang mit Ihren Ansprüchen machen.

Les qualités de Space?
Transparentes comme de l'eau de roche. Space est une gamme de meubles de salle de bains, pratiques et fonctionnels, qui s'intègrent dans tous les contextes.
Space propose différentes solutions personnalisables pour que votre salle de bains soit unique et accueillante, tout en respectant vos exigences.



Bruno Polliero Designer

Colori disponibili per il piano
Available colours for the top
Verfügbare Farbvarianten für den Waschtisch
Couleurs disponibles pour le plan

bianco
white
Weiß
blanc



faggio
beech
Buchenholz
hêtre



Colori disponibili per la struttura
Available colours for the structure
Verfügbare Farben für die Struktur
Couleurs disponibles pour la structure

bianco
white
Weiß
blanc



faggio
beech
Buchenholz
hêtre



Colori disponibili per le ante
Available colours for the doors
Verfügbare Farben für die Türen
Couleurs disponibles pour les portes

bianco
white
Weiß
blanc



faggio
beech
Buchenholz
hêtre



vetro
glass
Glas
verre



Colori disponibili per la maniglia
Available colours for the handle
Verfügbare Farben für den Griff
Couleurs disponibles pour la poignée

cromo
chromed
Verchromt
chromée



SPACE: IL BAGNO PER ECCELLENZA.
SPACE: THE BATHROOM PAR EXCELLENCE
SPACE: DAS BAD SCHLECHTHIN
SPACE: LA SALLE DE BAINS PAR EXCELLENCE.

Il mobile sottolavabo va a sostituire la colonna lavabo.

The under washbasin furniture that replaces the column.

Der Waschbecken-unterschrank ersetzt die Waschbeckensäule.

Le meuble sous-lavabo remplace la colonne du lavabo.

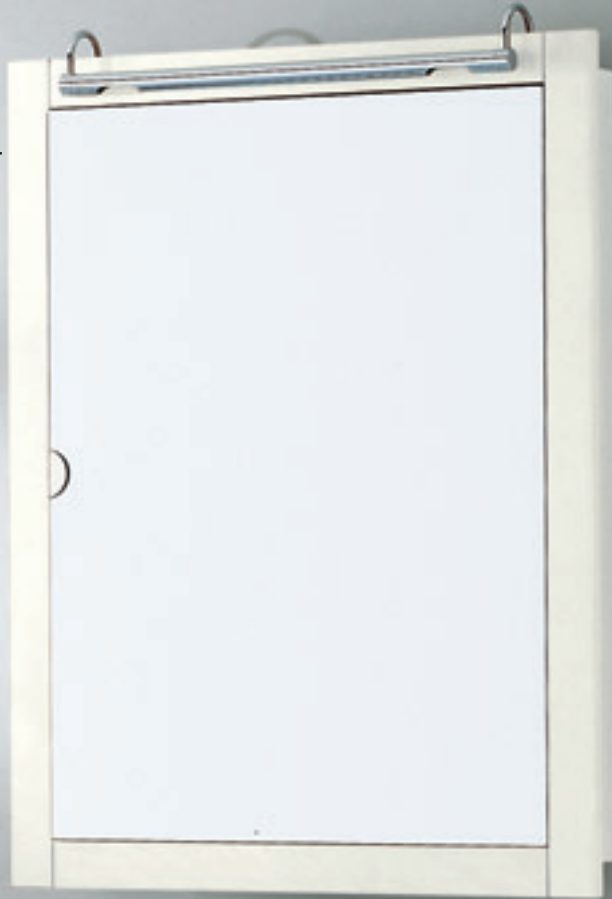

1

SPACE



IL CARRELLO ADATTO ALLE VOSTRE ESIGENZE
THE TROLLEY ACCORDING YOUR REQUIREMENTS
DER WAGEN NACH IHREM WUNSCH
LE CHARIOT QUI RÉPOND À TOUTES VOS EXIGENCES.



Carrello multifunzione con cesto portabiancheria asportabile in acciaio cromato.

Multifunctional trolley with removable laundry basket in chromium-plated steel.

Mehrzweckwagen mit abnehmbarem Wäschekorb aus verchromtem Stahl.

Chariot multifonction avec panier à linge extractible en acier chromé.



Carrello con anta e ripiani interni.

Trolley with door and inside shelves.

Wagen mit Tür und Innenfächern.

Chariot avec porte et tablettes intérieures.



Nella parte posteriore del carrello vi sono delle mensole portaoggetti; una particolare ribaltina permette di riporre il phon durante l'uso e, una volta chiusa, può contenerlo.

In the rear part of the trolley there are two shelves and special folding door to put your hair-drier while using it, and to hold it afterwards.

Im hinteren Teil des Wagens gibt es Konsolen und eine spezielle Klapptür um den Haartrockner während des Gebrauchs abzulegen und ihn anschließend darin aufzubewahren.

Des tablettes porte-objets sont montées derrière le chariot ; un support spécial permet de poser le sèche-cheveux pendant son utilisation et, une fois fermé, de le ranger.

1

SPACE





SPACE: SPAZIO ALLA FANTASIA.
SPACE: FREE YOUR IMAGINATION.
SPACE: PHANTASIEFREIHEIT
SPACE: PLACE À LA FANTASIE

Bianco faggio e vetro abbinabili in svariate combinazioni.

White, beech and glass...
different solutions.

Weiß, Buche und Glas ...
verschiedene
Kombinationsmöglichkeiten.

Blanc Hêtre et verre peuvent être
combinés dans différentes versions.













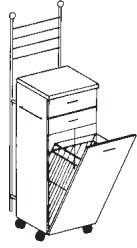











1
SPACE



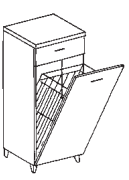

RIFLESSI DI VITA QUOTIDIANA SOTTO UNA GIUSTA LUCE
REFLECTIONS OF EVERYDAY LIFE, IN A NEW LIGHT
EINDRÜCKE DES TAGESLEBENS UNTER EINER RICHTIGEN LICHT
REFLETS DE LA VIE DE TOUS LES JOURS SOUS LE BON ÉCLAIRAGE







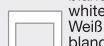
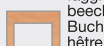
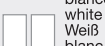
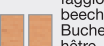





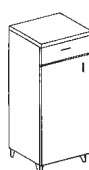

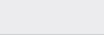
1

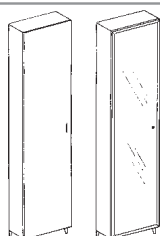

SPACE

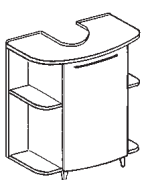
<p>PIANO TOP TOP DESSUS</p>	<p>Top in MDF, spessore mm. 25, postformato rivestito in PVC. Top made of MDF, thickness mm. 25, postformed covered with PVC. Vorgebildetes Top aus MDF, Tiefe mm., und mit PVC bezieht. Bandeau en MDF, épaisseur 25 mm, postformé revêtu de PVC.</p>	<p>bianco white Weiß blanc</p>	<p>faggio beech Buchenholz hêtre</p>	
<p>STRUTTURA STRUCTURE STRUKTUR STRUCTURE</p>	<p>La struttura è in nobilitato idrorepellente V100 sp.18mm nelle finiture bianco e faggio. The structure is made by 18-mm waterproof faced chipboard with white or beech finishings. Die Struktur ist aus wasserabstossender melaminbeschichteten Spanplatte mit 18 mm Stärke mit weißer oder Buchenholzer Vollendung La structure est en mélamine hydrofuge V100 épaisseur 18 mm en finition blanc et hêtre.</p>	<p>bianco white Weiß blanc</p>	<p>faggio beech Buchenholz hêtre</p>	
<p>ANTA DOOR TÜR PORTE</p>	<p>L'anta è in truciolare sp.18mm postformato. L'anta vetro ha un telaio in alluminio anodizzato ed un vetro sp.4mm acidato. The door is made by 18-mm-postformed chipboard. The glass door has profiles in anodized aluminium and a 4-mm-tempered glass. Die Tür ist aus vorgebildeter Spanplatte mit 18 mm Stärke. Die Glastür hat Profile aus eloxiertem Aluminium und ein Sekuritglass mit 4 mm Stärke. La porte est en aggloméré épaisseur 18 mm postformé. La porte en verre est munie d'un cadre en aluminium anodisé et un verre acidifié épaisseur 4 mm.</p>	<p>bianco white Weiß blanc</p>	<p>faggio beech Buchenholz hêtre</p>	<p>vetro glass Glas verre</p>

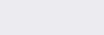
	<p>Descrizione - Description Beschreibung - Description</p>	<p>Prof. D. - T. - P.</p>	<p>Largh. W. - B. - L.</p>	<p>Altezza H. - H. - H.</p>	<p>Cerniera Hinges Scharniere Femoir</p>		
	<p>MOBILE CARRELLO Con cesto portabiancheria e cassetti. Completo di supporto e mensole. TROLLEY FURNITURE With laundry basket and drawers. Equipped with support and shelves. WAGENMÖBEL Mit Wäschekorb und Schubladen. Komplett mit Halterung und Konsolen. MEUBLE CHARIOT Avec panier, coffre à linge et tiroirs. Avec support et tablettes.</p>	35 cm	35 cm	97 cm 141 cm			
							
						M.101.120	M.101.140
							
						M.101.130	M.101.144
	<p>MOBILE CARRELLO Con anta, ripiani e cassetti. Completo di supporto e mensole. TROLLEY FURNITURE With door, shelves and drawers. Equipped with support and shelves. WAGENMÖBEL Mit Tür, Fächern und Schubladen. Komplett mit Halterung und Konsolen. MEUBLE CHARIOT Avec porte, étagères et tiroirs. Avec support et tablettes.</p>	35 cm	35 cm	97 cm 141 cm	<p>dx - right rechts - droit sx - left links - gauche</p>		
						M.101.220	M.101.240
						M.101.221	M.101.241
							
						M.101.230	M.101.244
						M.101.231	M.101.245
	<p>ARMADIO COLONNA Con ripiani cristallo amovibili. COLUMN CABINET With removable glass shelves. SÄULESCHRANK Mit abnehmbaren Glasfächern. ARMOIRE COLONNE Avec étagères amovibles en verre.</p>	25 cm	30 cm	186 cm	<p>dx - right rechts - droit sx - left links - gauche</p>		
						M.101.510	M.101.540
						M.101.511	M.101.541
							
						M.101.516	M.101.546
						M.101.517	M.101.547
	<p>MOBILE BASE Con cesto portabiancheria e cassetto. BASIC FURNITURE With laundry basket and drawers. GRUNDMÖBEL Mit Wäschekorb und Schubladen. MEUBLE BAS Avec panier, coffre à linge et tiroir.</p>	35 cm	35 cm	92 cm			
							
						M.101.320	M.101.340
							
						M.101.330	M.101.344

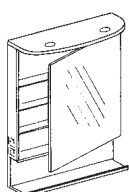
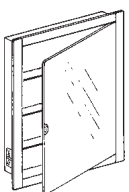
PIANO TOP TOP DESSUS		bianco white Weiß blanc		faggio beech Buchenholz hêtre		
STRUTTURA STRUCTURE STRUKTUR STRUCTURE		bianco white Weiß blanc		faggio beech Buchenholz hêtre		
ANTA DOOR TÜR PORTE		bianco white Weiß blanc		faggio beech Buchenholz hêtre		vetro glass Glas verre

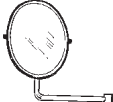
	Descrizione - Description Beschreibung - Description	Prof. D. - T. - P.	Largh. W. - B. - L.	Altezza H. - H. - H.	Cerniera Hinges Scharniere Fermoir		
	MOBILE BASE Con anta, ripiani e cassetto. BASIC FURNITURE With door, shelves and drawer. GRUNDMÖBEL Mit Tür, Fächern und Schublade. MEUBLE BAS Avec porte, étagères et tiroir.	35 cm	35 cm	92 cm	dx - right rechts - droit sx - left links - gauche		
						M.101.420	M.101.440
						M.101.421	M.101.441
							
	ARMADIO COLONNA Con ripiani cristallo amovibili. COLUMN CABINET With removable glass shelves. SAULESCHRANK Mit abnehmbaren Glasfächern. ARMOIRE COLONNE Avec étagères amovibles en verre.	25 cm	45 cm	186 cm	dx - right rechts - droit sx - left links - gauche		
						M.101.512	M.101.542
						M.101.513	M.101.543
							
	MOBILE SOTTOLAVABO Con anta curva e mensola laterali. UNDERWASHBASIN CABINET With curved door and side shelves. WASCHBECKENUNTERSCHRANK Mit gewölbter Tür und seitlichen Konsolen. MEUBLE SOUS LAVABO Avec porte arrondie et tablettes latérales. Piano e mensola faggio Beech to and shelves Buchenholze Konsolen und Top Plan et tablettes hêtre	49 cm	68 cm	66 cm	dx - right rechts - droit sx - left links - gauche		
						M.101.010	M.101.040
						M.101.011	M.101.041
							
	SPECCHIERA CON MENSOLA Specchiera con elemento contenitore nel retro specchio. Mensola, 2 faretti alogeni, interruttore e presa elettrica. MIRROR CABINET WITH SHELF Mirror cabinet with container piece in back of mirror, shelves, two halogen spotlights, switch and electrical socket. WANDSPIEGEL MIT KONSOLE Wandspiegel mit Behälterelement hinter dem Spiegel, Konsolen, zwei Halogenstrahler, Schalter und Steckdose. MIROIR AVEC TABLETTE Miroir avec élément à compartiment à l'arrière du miroir. Tablette, 2 spots halogènes, interrupteur et prise électrique.	12 cm	65 cm	88 cm	dx - right rechts - droit sx - left links - gauche	M.101.990	
						M.101.991	
	SPECCHIERA A TELAIO Specchiera con telaio in massello di legno. Elemento contenitore nel retro specchio, interruttore e presa elettrica. FRAMED MIRROR CABINET Mirror cabinet with frames in solid beech, container piece in back of mirror, switch and electrical socket. WANDSPIEGEL MIT RAHMEN Wandspiegel mit Rahmen aus massivem Buchenholz, Behälterelement hinter dem Spiegel, Schalter und Steckdose. MIROIR SUR CADRE Miroir sur cadre en bois massif. Élément à compartiment à l'arrière du miroir, interrupteur et prise électrique.	12 cm	65 cm	85 cm	dx - right rechts - droit sx - left links - gauche	M.101.982	M.101.980
						M.101.983	M.101.981

	Descrizione - Description Beschreibung - Description	Prof. D. - T. - P.	Largh. W. - B. - L.	Altezza H. - H. - H.	
	<p>Specchio ingranditore con supporto per specchiere e carrelli (diam. cm.20)</p> <p>Enlarger mirror with support for mirror cabinets and trolleys, diameter 20 cm.</p> <p>Vergrößerungsspiegel mit Halterung für Wandspiegel und Wagen. Durchmesser 20 cm.</p> <p>Miroir grossissant avec support pour miroir et chariots (diam. 20 cm).</p>	-	-	-	M.399.002.010
	<p>Lampada cromata per specchiera a telaio.</p> <p>Chromed lamp for framed mirror cabinet.</p> <p>Verchromte Lampe für Wandspiegel mit Rahmen.</p> <p>Applique chromée pour miroir sur cadre.</p>	-	60 cm	-	M.399.590.010
	<p>Lampada cromata per specchiera a telaio.</p> <p>Chromed lamp for framed mirror cabinet.</p> <p>Verchromte Lampe für Wandspiegel mit Rahmen.</p> <p>Applique chromée pour miroir sur cadre.</p>	-	22 cm	-	M.399.591.002

Opla è un mobile capace ed essenziale da mettere sotto il vostro lavabo
 Opla è un monoblocco capace ed essenziale, che sostituisce la colonna, completando il lavabo grazie alla regolazione in altezza dei piedini in acciaio. Sebbene di dimensioni contenute, è pratico, funzionale e capiente; e riesce a soddisfare le vostre esigenze. Questo elemento è molto utile per chi ha problemi di spazio nei locali di servizio e vuole allo stesso tempo raggiungere l'armonia estetica.
 Opla è quello che cercate. Basta togliere la colonna del lavabo e inserirlo al suo posto senza dover intervenire sull'impianto idraulico.
 I piedini si regolano in altezza, mentre la speciale guarnizione si adegua perfettamente ad ogni tipo di lavabo.

Opla is a capacious and essential furniture to be placed under the washbasin.
 Opla is a capacious and essential unit which replaces the column completing the washbasin and supporting it thanks to the height adjustable feet. Even if the dimensions are contained, Opla is practical, functional and capacious and it meets your requirements.
 This furniture is very useful for space problems in the service rooms and at the same time it wants to reach the aesthetic harmony.
 Opla is what you are looking for. It is enough to remove the column of the washbasin and insert it without intervene in the plumbing.
 The feet are adjustable in height and the special washer adapts itself to every kind of washbasin.

Opla ist ein geräumiges und hauptsächlichliches Möbel, das unter das Washbecken gestellt werden kann.
 Opla ist ein geräumiges und hauptsächlichliches Möbel, das die Waschbeckensäule ersetzt und das Waschbecken mit den hohenvestellbaren Füßen stützt.
 Obwohl seine Maßen enthalten sind, ist dieses Möbel praktisch, zweckmäßig und geräumig und es kann Ihre Ansprüchen entsprechen.
 Das Möbel ist nützlich für Raumprobleme und will zur selben Zeit die ästhetische Harmonie erreichen.
 Opla ist was Sie suchen. Es ist genug die Waschbeckensäule zu entfernen und Opla unter das Waschbecken schieben.
 Die Hohe der Füße kann verstellt sein während die Dichtung sich an jede Waschbecken anpasst.

Opla est un meuble de grande capacité à la ligne essentielle, à installer sous votre lavabo ; Opla est un monobloc fonctionnel qui remplace la colonne en s'adaptant parfaitement au lavabo grâce au réglage en hauteur des pieds en acier. Bien que de dimensions réduites, il est pratique, fonctionnel, et sa grande capacité répond à toutes vos exigences. Cet élément s'avère très utile pour en cas de problèmes de place dans la salle de bains et pour qui souhaite les résoudre tout en préservant l'esthétique. Opla est la solution que vous cherchez. Il suffit d'enlever la colonne du lavabo et de mettre le meuble à sa place, sans intervenir sur l'installation hydraulique. Les pieds sont réglables en hauteur et le joint spécial s'adapte parfaitement à tous les types de lavabo.

Colori disponibili per la struttura
 Available colours for the structure
 Verfügbare Farben für die Struktur
 Couleurs disponibles pour la structure

bianco
 white
 Weiß
 blanc 

Colori disponibili per le ante
 Available colours for the doors
 Verfügbare Farben für die Türen
 Couleurs disponibles pour les portes

bianco
 white
 Weiß
 blanc 

Colori disponibili per il pomolo
 Available colours for the knob
 Verfügbare Farben für den Türknauf
 Couleurs disponibles pour le pommeau

alluminio satinato
 mat aluminium
 Matt Aluminium
 satinée 



Opla soddisfa ogni vostra esigenza senza trascurare il buon gusto del design.

Opla meets your requirements without neglecting the good design taste.

Opla entspricht ihre ansprüchen ohne den designgeschmack zu vernachlässigen.

Opla satisfait vos exigences sans renoncer au bon goût du design.

2

OPLA

Il design e la praticità degli armadi colonna della serie Space ben si intonano alle caratteristiche di Opla.

The design and the practicality of the column cupboards in the Space range fit in well with the characteristics of Opla.



Design und Funktionalität der Säulenschränke aus der Linie Space fügen sich optimal in die Merkmale von Opla ein.



Le design et la praticité des armoires colonne de la série Space s'accordent bien avec les caractéristiques d'Opla.



16 - Montegrappa

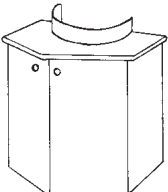
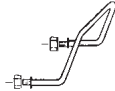
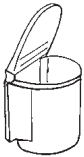

<p>STRUTTURA STRUCTURE STRUKTUR STRUCTURE</p>	<p>Struttura idrorepellente V100. Structure made by waterproof faced chipboard V100. Struktur aus wasserabstoßender melaminbeschichteten Spanplatte V100. Structure hydrofuge V100.</p>	 <p>bianco white Weiß blanc</p>
<p>ANTA DOOR TÜR PORTE</p>	<p>Antine truciolare postformato in laminato bianco. Doors made by postformed chipboard faced with white laminate. Türen aus mit weissem Laminat beschichteter vorgebildeten Spanplatte. Portes en aggloméré postformé en stratifié blanc.</p>	 <p>bianco white Weiß blanc</p>
<p>POMOLO KNOB TÜRKNÄUF POMMEAU</p>	<p>Pomolo finitura alluminio satinato Knob with glazed aluminium finish Türknauf mit mattierter Aluminiumdeckschicht Pommeau finition aluminium satin</p>	 <p>alluminio satinato mat aluminium Matt Aluminium satinée</p>

	<p>Descrizione - Description Beschreibung - Description</p>	<p>Prof. D. - T. - P.</p>	<p>Largh. W. - B. - L.</p>	<p>Altezza H. - H. - H.</p>	
	<p>Sottolavabo con piano in policarbonato e guarnizione in pivilene Underwashbasin furniture with top made by polycarbonate and pivilene washer Unterwaschbeckenmöbel mit Oberseite aus Polykarbonat und Dichtung aus Pivilene Sous lavabo avec plan en polycarbonate et joint en pivilene</p>	<p>50 cm</p>	<p>61 cm</p>	<p>62 cm</p>	<p>M.130.002</p>
	<p>Portasciugamani in ottone cromato Towel rack made by chromium plated brass Handtuchhalter aus verchromtem Messing Porte-serviettes en laiton chromé</p>	<p>-</p>	<p>-</p>	<p>-</p>	<p>M.399.580.001</p>
	<p>Pattumiera per bagno Garbage can Abfalleimer Poubelle pour salle de bain</p>	<p>-</p>	<p>-</p>	<p>-</p>	<p>M.399.401.001</p>
	<p>Portalampada cromato Lamp holder Lampenfassung Applique chromée</p>	<p>-</p>	<p>-</p>	<p>-</p>	<p>M.399.590.002</p>
	<p>Specchio Mirror Spiegel Miroir</p>	<p>-</p>	<p>60 cm</p>	<p>75 cm</p>	<p>M.399.002.002</p>

GIADA

Montegrappa®

Giada è un programma formato da blocchi lavabo per serie ad incasso e da un'ampia gamma di complementi quali basi, pensili, colonne e carrelli. Le forme morbide ben si abbinano agli accostamenti cromatici disponibili, creando un insieme sobrio ed elegante. La grande praticità, tipica dei prodotti Montegrappa, ne rende l'utilizzo piacevole anno dopo anno.

Giada is a line of wash basin blocks for inbuilt series and includes a wide range of complementary articles such as bases, wall units, tall cabinets and trolleys. The soft forms go well with the matching available colours, creating a sober and elegant overall look. The great practicality, typical of Montegrappa products, makes them pleasant to use year after year.

Giada ist eine Produktlinie, die aus serienmäßigen Einbauwaschtischen und einer großen Auswahl von Einzelteilen wie Unter-, Hänge-, Hoch- und Rollschränken besteht. Die weichen Formen verbinden sich gut mit den erhältlichen Farbausführungen und bilden eine klassische und elegante Einheit. Der Gebrauch dieser Möbel wird durch ihre große Zweckmäßigkeit, die typisch für alle Montegrappa-Produkte ist, Jahr für Jahr zu einem Vergnügen.

Giada est un programme composé de blocs lavabo pour série à encastrer et d'une vaste gamme de compléments : meubles bas, meubles hauts, colonnes et chariots. Ses formes douces s'harmonisent bien avec les combinaisons de couleurs disponibles et créent un ensemble sobre et élégant. Très pratiques, comme tous les produits Montegrappa, année après année vous ne vous en lasserez pas.



Colori disponibili per il piano
Available colours for the top
Verfügbare Farbvarianten für den Waschtisch
Couleurs disponibles pour le plan

PVC marmo
PVC marble
PVC Marmor
PVC marbre

faggio
beech
Buchenholz
hêtre

Colori disponibili per la struttura
Available colours for the structure
Verfügbare Farben für die Struktur
Couleurs disponibles pour la structure

bianco
white
Weiß
blanc

faggio
beech
Buchenholz
hêtre

Colori disponibili per le ante
Available colours for the doors
Verfügbare Farben für die Türen
Couleurs disponibles pour les portes

bianco
white
Weiß
blanc

faggio
beech
Buchenholz
hêtre

blu
blue
Blau
bleu

giallo
yellow
Gelb
jaune

vetro
glass
Glas
verre

Colori disponibili per la maniglia
Available colours for the handle
Verfügbare Farben für den Griff
Couleurs disponibles pour la poignée

cromo
chromed
Verchromt
chromée



3

GIADA

3

GIADA

Giada è caratterizzato dalle forme morbide e sobrie, ma anche da dettagli che esprimono una personalità decisa.

Giada features soft, sober forms, but also details that express a strong personality.

Giada zeichnet sich durch weiche und klassische Formen, aber auch durch Details, die eine entschiedene Persönlichkeit ausdrücken, aus.

Giada se reconnaît à ses formes douces et essentielles mais aussi à ses détails, qui expriment un caractère décidé.





**STRUTTURA
STRUCTURE
STRUKTUR
STRUCTURE**

La struttura è in nobilitato idrorepellente V100 sp.18 mm nei colori bianco, faggio. Il lavabo è in poliestere rinforzato con fibra di vetro (P.R.F.V.)
The structure is in 18 mm V100 water-repellent laminate in white and beech. The basin is in fibreglass-reinforced polyester (F.R.P.)
Die Struktur ist mit flüssigkeitsabweisenden V100, Stärke 18 mm veredelt und in den Farben Weiß und Buche erhältlich. Der Waschtisch ist aus glasfaserverstärktem Polyester (GFK) hergestellt.
La structure est en mélamine hydrofuge V100 épaisseur 18 mm, en couleurs blanc et hêtre. Le lavabo est en polyester renforcé avec fibres de verre (P.R.F.V.)





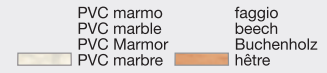





**PIANO
TOP
TOP
DESSUS**

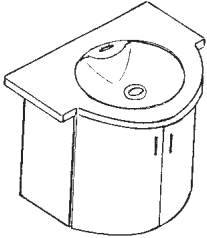

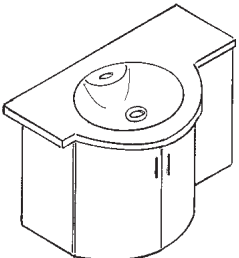

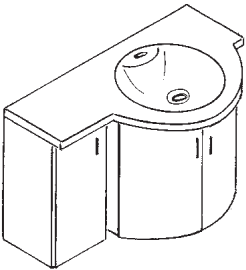
Top in MDF, postformato rivestito in PVC.
Top made of MDF, postformed covered with PVC.
Vorgebildetes Top aus MDF, und mit PVC bezieht.
Bandeau en MDF, postformé, revêtu de PVC.













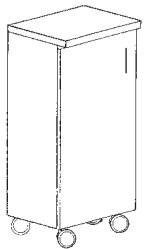





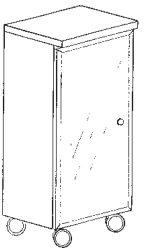



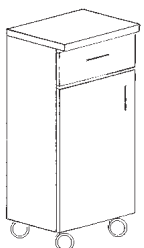



**ANTA
DOOR
TÜR
PORTE**

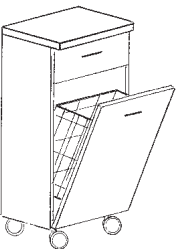





L'anta è in truciolare sp.18 mm postformato nei colori bianco, faggio, blu, giallo e in vetro temperato da 4 mm. L'anta vetro ha un telaio in alluminio anodizzato ed un vetro sp.4 mm acidato.
The door is in 18 mm post-formed chipboard in white, beech, blue, yellow and in 4 mm tempered glass. The glass door has an anodised aluminium frame and 4 mm acid-etched glass.
Die Tür ist in Spanplatte, Stärke 18 mm, in den Farben Weiß, Eiche, Blau, Gelb und in Hartglas, Stärke 4 mm, lieferbar. Die Glastür verfügt über einen eloxierten Aluminiumrahmen und ist aus geätztem Glas, Stärke 4 mm.
La porte est en aggloméré épaisseur 18 mm postformé en blanc, hêtre, bleu, jaune et en verre trempé de 4 mm. La porte en verre est munie d'un cadre en aluminium anodisé et en verre épaisseur 4 mm acidifié.



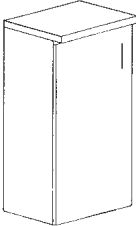
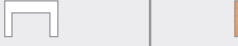

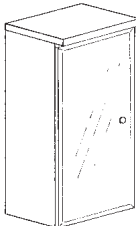
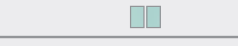
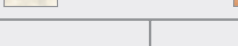
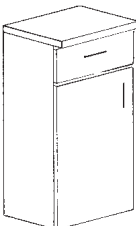

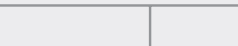
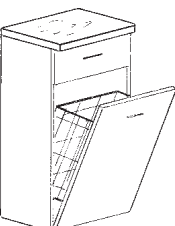

















	Descrizione - Description Beschreibung - Description	Prof. D. - T. - P.	Largh. W. - B. - L.	Altezza H. - H. - H.		
	BLOCCO LAVABO cm. 90 BASIN UNIT cm. 90 BLOCK WASCHTISCH cm 90 BLOC LAVABO 90 cm	27-54 cm	90 cm	63 cm		
	BLOCCO LAVABO cm. 115 versione destra BASIN UNIT cm. 115 right version BLOCK WASCHTISCH cm 115 Version rechts BLOC LAVABO 115 cm version droite	27-54 cm	115 cm	63 cm		
	BLOCCO LAVABO cm. 115 versione sinistra BASIN UNIT cm. 115 left version BLOCK WASCHTISCH cm 115 Version links BLOC LAVABO 115 cm version gauche	27-54 cm	115 cm	63 cm		

STRUTTURA STRUCTURE STRUKTUR STRUCTURE	 bianco white Weiß blanc  faggio beech Buchenholz hêtre
PIANO TOP TOP DESSUS	 PVC marmo PVC marble PVC Marmor PVC marbre  faggio beech Buchenholz hêtre
ANTA DOOR TÜR PORTE	 bianco white Weiß blanc  faggio beech Buchenholz hêtre  blu blue Blau bleu  giallo yellow Gelb jaune  vetro glass Glas verre

	Descrizione - Description Beschreibung - Description	Prof. D. - T. - P.	Largh. W. - B. - L.	Altezza H. - H. - H.	Cerniera Hinges Scharniere Fermoir	 
	CARRELLO con ripiani in cristallo amovibili TROLLEY with movable glass shelves WAGEN mit verstellbaren Kristallfächern CHARIOT avec étagères amovibles en verre	35 cm	35 cm	95 cm	dx - right rechts - droit sx - left links - gauche	   
						 
	CARRELLO con ripiani in cristallo amovibili TROLLEY with movable glass shelves WAGEN mit verstellbaren Kristallfächern CHARIOT avec étagères amovibles en verre	35 cm	35 cm	95 cm	dx - right rechts - droit sx - left links - gauche	
						 
	CARRELLO con cassetto e con ripiani in cristallo amovibili TROLLEY with drawer and movable glass shelves WAGEN mit Schubfach und verstellbaren Kristallfächern CHARIOT avec tiroir et étagères amovibles en verre	35 cm	35 cm	95 cm	dx - right rechts - droit sx - left links - gauche	   
						 
	CARRELLO con cesto e cassetto TROLLEY with basket and drawer WAGEN mit Korb und Schubfach CHARIOT avec panier et tiroir	35 cm	35 cm	95 cm	dx - right rechts - droit sx - left links - gauche	   
						 

STRUTTURA STRUCTURE STRUKTUR STRUCTURE		bianco white Weiß blanc		faggio beech Buchenholz hêtre		bianco white Weiß blanc		faggio beech Buchenholz hêtre			
PIANO TOP TOP DESSUS		bianco white Weiß blanc		faggio beech Buchenholz hêtre		PVC marmo PVC marble PVC Marmor PVC marbre		faggio beech Buchenholz hêtre			
ANTA DOOR TÜR PORTE		bianco white Weiß blanc		faggio beech Buchenholz hêtre		blu blue Blau bleu		giallo yellow Gelb jaune		vetro glass Glas verre	
	Descrizione - Description Beschreibung - Description	Prof. D. - T. - P.	Largh. W. - B. - L.	Altezza H. - H. - H.	Cerniera Hinges Scharniere Fermoir						
	BASE SOSPESO con ripiani in cristallo amovibili SUSPENDED UNIT with movable glass shelves HÄNGEBASIS mit verstellbaren Kristallfächern BASE SUSPENDUE avec étagères amovibles en verre	35 cm	35 cm	86 cm	dx - right rechts - droit sx - left links - gauche					M.104.530	M.104.630
						M.104.531	M.104.631				
	BASE SOSPESO con ripiani in cristallo amovibili SUSPENDED UNIT with movable glass shelves HÄNGEBASIS mit verstellbaren Kristallfächern BASE SUSPENDUE avec étagères amovibles en verre	35 cm	35 cm	86 cm	dx - right rechts - droit sx - left links - gauche					M.104.532	M.104.632
						M.104.533	M.104.633				
	BASE SOSPESO con cassetto e con ripiani in cristallo amovibili SUSPENDED UNIT with drawer and movable glass shelves HÄNGEBASIS mit Schublade und verstellbaren Kristallfächern BASE SUSPENDUE avec tiroir et étagères amovibles en verre	35 cm	35 cm	86 cm	dx - right rechts - droit sx - left links - gauche					M.104.534	M.104.634
						M.104.535	M.104.635				
	BASE SOSPESO con cesto e cassetto SUSPENDED UNIT with basket and drawer HÄNGEBASIS mit Korb und Schubfach BASE SUSPENDUE avec panier et tiroir	35 cm	35 cm	86 cm						M.104.538	M.104.638

STRUTTURA STRUCTURE STRUKTUR STRUCTURE	 bianco white Weiß blanc  faggio beech Buchenholz hêtre
ANTA DOOR TÜR PORTE	 bianco white Weiß blanc  faggio beech Buchenholz hêtre  blu blue Blau bleu  giallo yellow Gelb jaune  vetro glass Glas verre

	Descrizione - Description Beschreibung - Description	Prof. D. - T. - P.	Largh. W. - B. - L.	Altezza H. - H. - H.	Cerniera Hinges Scharniere Ferroir	 	
	PENSILE con ripiani in cristallo amovibili WALL UNIT with movable glass shelves HÄNGESCHRANK mit verstellbaren Kristallfächern ARMOIRE SUSPENDUE avec étagères amovibles en verre	17 cm	25 cm	85 cm	dx - right rechts - droit sx - left links - gauche	   	M.104.550
						M.104.551	M.104.650
	PENSILE con ripiani in cristallo amovibili WALL UNIT with movable glass shelves HÄNGESCHRANK mit verstellbaren Kristallfächern ARMOIRE SUSPENDUE avec étagères amovibles en verre	17 cm	25 cm	85 cm	dx - right rechts - droit sx - left links - gauche		M.104.552
						M.104.553	M.104.652
	PENSILE con ripiani in cristallo amovibili WALL UNIT with movable glass shelves HÄNGESCHRANK mit verstellbaren Kristallfächern ARMOIRE SUSPENDUE avec étagères amovibles en verre	25 cm	25 cm	85 cm	dx - right rechts - droit sx - left links - gauche	   	M.104.554
						M.104.555	M.104.654
	PENSILE con ripiani in cristallo amovibili WALL UNIT with movable glass shelves HÄNGESCHRANK mit verstellbaren Kristallfächern ARMOIRE SUSPENDUE avec étagères amovibles en verre	25 cm	25 cm	85 cm	dx - right rechts - droit sx - left links - gauche		M.104.556
						M.104.557	M.104.656

STRUTTURA
STRUCTURE
STRUKTUR
STRUCTURE



bianco
white
Weiß
blanc



faggio
beech
Buchenholz
hêtre

ANTA
DOOR
TÜR
PORTE



bianco
white
Weiß
blanc



faggio
beech
Buchenholz
hêtre



blu
blue
Blau
bleu



giallo
yellow
Gelb
jaune



vetro
glass
Glas
verre

	Descrizione - Description Beschreibung - Description	Prof. D. - T. - P.	Largh. W. - B. - L.	Altezza H. - H. - H.	Cerniera Hinges Scharniere Ferroir		
	<p>COLONNA con ripiani in cristallo amovibili COLUMN with movable glass shelves SÄULE mit verstellbaren Kristallfächern COLONNE à étagères amovibles en verre</p>	25 cm	30 cm	180 cm	<p>dx - right rechts - droit sx - left links - gauche</p>		
						M.104.580 M.104.581	M.104.680 M.104.681
	<p>COLONNA con ripiani in cristallo amovibili COLUMN with movable glass shelves SÄULE mit verstellbaren Kristallfächern COLONNE à étagères amovibles en verre</p>	25 cm	30 cm	180 cm	<p>dx - right rechts - droit sx - left links - gauche</p>		
						M.104.582 M.104.583	M.104.682 M.104.683
	<p>COLONNA con ripiani in cristallo amovibili COLUMN with movable glass shelves SÄULE mit verstellbaren Kristallfächern COLONNE à étagères amovibles en verre</p>	25 cm	45 cm	180 cm	<p>dx - right rechts - droit sx - left links - gauche</p>		
						M.104.584 M.104.585	M.104.684 M.104.685
	<p>COLONNA con ripiani in cristallo amovibili COLUMN with movable glass shelves SÄULE mit verstellbaren Kristallfächern COLONNE à étagères amovibles en verre</p>	25 cm	45 cm	180 cm	<p>dx - right rechts - droit sx - left links - gauche</p>		
						M.104.586 M.104.587	M.104.686 M.104.687

STRUTTURA
STRUCTURE
STRUKTUR
STRUCTURE

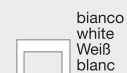

bianco
white
Weiß
blanc



faggio
beech
Buchenholz
hêtre

	Descrizione - Description Beschreibung - Description	Prof. D. - T. - P.	Largh. W. - B. - L.	Altezza H. - H. - H.	Cerniera Hinges Scharniere Fermoir		
	SPECCHIERA A TELAIO MIRROR WITH FRAMEWORK WANDSPIEGEL MIT RAHMEN MIROIR SUR CADRE	12 cm	65 cm	85 cm	dx - right rechts - droit sx - left links - gauche	M.104.982 M.104.983	M.104.980 M.104.981

	Descrizione - Description Beschreibung - Description	Prof. D. - T. - P.	Largh. W. - B. - L.	Altezza H. - H. - H.	
	SPECCHIO con cornice sabbiata MIRROR with sand-blasted frame SPIEGEL mit matteden Rahmen (Sandstrahlung) MIROIR à cadre sablé	3 cm	55 cm	85 cm	M.399.002.005
	LAMPADA con alogena LAMP with halogen LAMPE mit Halogenlampe LAMPE halogène	14 cm	22 cm	-	M.399.591.005
	PORTA SALVIETTE ESTRAIBILE in alluminio PULL-OUT TOWEL RAIL in aluminium KOSMETIKTUCHSPENDER aus Aluminium PORTE-SERVIETTES ESCAMOTABLE	-	-	-	M.399.580.006

3

GIADA

MOBILAVA

Montegrappa®

Mobilava: uno stile di vita.
Mobilava ha tre entità:
mobile, lavabo, lavatoio.
Ha struttura in nobilitato
idrorepellente V100, anta
postformata in orizzontale
e vasca in metacrilato
bianco lucido.

Mobilava: a lifestyle.
Mobilava has three
elements: furniture,
sink and trough.
The structure is made by
waterproof faced chipboard
V100, postformed door and
basin in white methacrylate.

Mobilava: ein lebensstil.
Mobilava hat drei Elemente:
Möbel, Waschbecken und
Trog. Die Struktur ist aus
wasserabstoßender
melaminbeschichteten
Spanplatte, vorgebildere
Türen und Becken aus
weißem Methacrylat.

Mobilava: un style de vie.
Mobilava se compose de trois
parties: meuble, lavabo,
lavoir. Il a une structure en
panneau de particules
hydrofuges V100, une porte
postformée horizontale et une
vasque en méthacrylate blanc
brillant.

Struttura in nobilitato idrorepellente V100, anta in truciolare
postformato in orizzontale e vasca in metacrilato bianco lucido.
Structure made by waterproof faced chipboard V100, postformed
doors and washbasin in white methacrylate.
Struktur aus wasserabstoßender melaminbeschichteten
Spanplatte V100, vorgebildere Türen und Waschbecken aus
weißem Methacrylat.
Structure en mélanine hydrofuge V100, porte en aggloméré
postformé en horizontale et vasque en méthacrylate blanc brillant.

Colori disponibili per le ante
Available colours for the doors
Verfügbare Farben für die Türen
Couleurs disponibles pour les portes

Colori disponibili per la maniglia
Available colours for the handle
Verfügbare Farben für den Griff
Couleurs disponibles pour la poignée

bianco
white
Weiß
blanc





bianco
white
Weiß
blanc



cromo
chromed
Verchromt
chromée

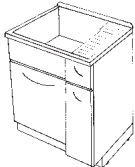

	Descrizione - Description Beschreibung - Description	Prof. D. - T. - P.	Largh. W. - B. - L.	Altezza H. - H. - H.	
	Con cestone portabiancheria With laundry basket Mit Wäschekorb Avec panier à linge	50 cm	70 cm	88 cm	M.120.050
	Specchio Mirror Spiegel Miroir	-	60 cm	75 cm	M.399.002.002
	Portalampada cromato Lamp holder Lampenfassung Applique chromée	-	-	-	M.399.590.002



STEND-ART

Montegrappa®

Tre funzioni in un unico elemento: specchio, contenitore, stendibiancheria. Stend-Art è un comodo contenitore che racchiude delle mensole portaoggetti con possibile specchiera; inoltre all'occorrenza si trasforma in un utile stendibiancheria. Stend-Art per le sue molteplici funzioni può essere inserito in più contesti all'interno di una casa.

Three functions in a sole element: mirror, cabinet and drying rack. Stend-Art is a comfortable cabinet which contains shelves with a potential mirror, and in case of need it turns into a useful drying rack. Stend-Art could be placed in every space inside the house thanks to its various functions

Drei Funktionen in einem einzigen Element: Spiegel, Schrank und Wäschetrockner. Stend-Art ist einen bequemen Schrank, der Fächer und einen Spiegel enthält und bei Bedarf sich in einen Wäschetrockner verwandelt. Stend-Art kann in jedes Raum des Hauses dank ihrem vielfältigen Funktionen gestellt werden.

Trois fonctions en un seul élément : miroir, compartiment de rangement, sèche-linge. Stend-Art est un meuble de rangement pratique qui contient des tablettes porte-objets avec possibilité d'ajouter un miroir ; de plus, il se transforme à l'occurrence en sèche-linge très utile. Grâce à ses nombreuses fonctions, Stend-Art peut être placé dans tout endroit de la maison.



Stend-Art con specchio.
Stend-Art with mirror.
Stend-Art mit Spiegel.
Stend-Art avec miroir.



Stend-Art senza specchio.
Stend-Art without mirror.
Stend-Art ohne Spiegel.
Stend-Art sans miroir.



Colori disponibili per lo schienale
Colours available for the back rest
Verfügbare Farbvarianten für die Lehne
Coloris du panneau postérieur.

bianco
white
Weiß
blanc



giallo
yellow
gelb
jaune



verde acqua
water green
Wassergrün
vert d'eau



**QUALITÀ E FUNZIONALITÀ INTERPRETATI
ALLA BASE DI PRINCIPI ESTETICI ATTUALI.**

QUALITY AND FUNCTIONALITY ARE INTERPRETED
ON THE BASIS OF PRESENT AESTHETICS
PRINCIPLES.

QUALITÄT UND ZWECKMÄßIGKEIT SIND AUF
GRUND DER AKTUELLEN
ÄSTHETISCHEN GRUNDSÄTZE AUSGELEGT.

LA QUALITÉ ET LA FONCTIONNALITÉ
INTERPRÉTÉES EN FONCTION DES PRINCIPES
ESTHÉTIQUES ACTUELS

5

STEND-ART





**STRUTTURA
STRUCTURE
STRUKTUR
STRUCTURE**

Realizzato con profilati di alluminio anodizzato, nell'interno trovano alloggio comode mensole di cristallo.
Le due griglie stendibiancheria sono realizzate in ferro trafilato verniciato a forno di colore alluminio, quindi protette con speciale vernice trasparente.
La separazione tra il vano contenitore e lo stendibiancheria è realizzata in laminato a spessore, particolarmente resistente agli agenti atmosferici.
It is realized with anodized aluminium section bars and at its inside there are comfortable glass shelves.
The two drying rack grills are made by aluminium painted drawn iron and then protected with a special transparent varnish.
The division between the container piece and the drying rack is made by laminate.
Es ist mit Profilen aus eloxiertem Aluminium hergestellt und in der Innereiseite gibt es bequeme Glasfächer.
Die zwei Gitter zum Wäschetrockner sind aus Aluminium gefärbtem gezogenen Stahl, der mit einer Transparenzlack beschichtet ist.
Das Trennteil zwischen den Schrank und den Wäschetrockner ist aus Laminat.
Réalisé en profilés d'aluminium anodisé. L'intérieur renferme de pratiques tablettes en verre.
Les deux grilles sèche-linge sont fabriquées en fer étiré vernies au four, de couleur aluminium, puis protégées par une peinture spécifique transparente.
La séparation entre le compartiment et le sèche-linge est réalisée en stratifié d'épaisseur particulièrement résistante aux agents atmosphériques.

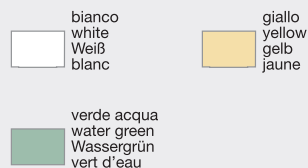
Colori pannello:
Panel Colours:
Farben für Platte:
Couleurs cloison:

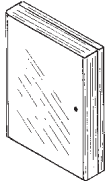
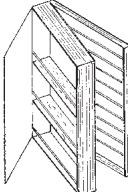
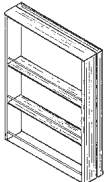
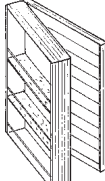

	Descrizione - Description Beschreibung - Description	Prof. D. - T. - P.	Largh. W. - B. - L.	Altezza H. - H. - H.	Cerniera Hinges Scharniere Ferroir				
	Con Specchio chiuso With mirror closed Mit Spiegel Geschlossen Avec miroir fermé	13 cm	55 cm	75 cm	dx - right rechts - droit sx - left links - gauche				
									M.102.010 M.102.011
	Con Specchio aperto With mirror open Mit Spiegel Geöffnet Avec miroir ouvert	72 cm	64 cm	75 cm	dx - right rechts - droit sx - left links - gauche				
	Chiuso Closed Geschlossen Fermé	13 cm	55 cm	75 cm					M.102.000 M.102.001
	Aperto Open Geöffnet Ouvert	72 cm	64 cm	75 cm					

Synthesis di Montegrappa presenta soluzioni e dettagli accuratamente elaborati, caratterizzati dall'elegante accostamento legno-vetro. Un programma composto da mobili e piani porta lavabo, colonne portaoggetti, contenitori e mensole in legno o cristallo, declinato in 3 differenti versioni: con fianchi a terra, sospeso oppure con piedini in finitura alluminio. Tre modi diversi di intendere l'eleganza e la sobrietà di Synthesis.

Synthesis by Montegrappa presents accurately developed solutions and details, featuring elegantly matched wood-glass combinations. A line made up of furniture and wash basin surrounds, tall cabinets, containers and shelves in wood and crystal, designed in 3 different versions: with cupboard sides to the floor, suspended, or on aluminium-finished feet. Three different ways of presenting the elegance and sobriety of Synthesis.

Synthesis von Montegrappa präsentiert Designlösungen und Details, die sorgfältig ausgefeilt und durch die elegante Vereinigung von Holz und Glas gekennzeichnet sind. Die Produktlinie besteht aus Waschtischmöbeln und Untertischen, Hochschränken mit Ablagefächern, Behältern und Konsolen aus Holz oder Kristall, von denen es drei verschiedene Versionen gibt: stehend, hängend oder mit Füßen aus Aluminiumrohr. Drei unterschiedliche Arten, wie man die Eleganz und Klassik von Synthesis verstehen kann.

Synthesis de Montegrappa présente des solutions et des détails soigneusement élaborés, caractérisés par l'élégance du verre et du bois. Un programme qui se compose de meubles et de plan porte-lavabo, de colonnes de rangement, de modules et d'étagères en bois ou en verre, et qui se décline en trois versions au choix : avec parois latérales au sol, suspendu ou avec pieds d'appui en aluminium. Trois façons différentes de concevoir l'élégance et la sobriété de Synthesis.



Colori disponibili per il piano
Available colours for the top
Verfügbare Farbvarianten für den Waschtisch
Couleurs disponibles pour le plan

acero
maple
Ahornholz
érable

faggio
beech
Buchenholz
hêtre

wengé
wengé
Wengé
wengé

vetro
glass
Glas
verre

Colori disponibili per la struttura
Available colours for the structure
Verfügbare Farben für die Struktur
Couleurs disponibles pour la structure

bianco
white
Weiß
blanc

faggio
beech
Buchenholz
hêtre

wengé
wengé
Wengé
wengé

acero
maple
Ahornholz
érable

Colori disponibili per le ante
Available colours for the doors
Verfügbare Farben für die Türen
Couleurs disponibles pour les portes

bianco
white
Weiß
blanc

faggio
beech
Buchenholz
hêtre

wengé
wengé
Wengé
wengé

acero
maple
Ahornholz
érable

blu
blue
Blau
bleu

giallo
yellow
Gelb
jaune

vetro
glass
Glas
verre



6

SYNTHESIS



SYNTHESIS CON FIANCHI A TERRA.
SYNTHESIS WITH SIDES TO THE FLOOR.
SYNTHESIS MIT DEN SEITEN ALS BODENSTÜTZEN.
SYNTHESIS AVEC PANNEAUX LATÉRAUX AU SOL.

La linea delle colonne sospese e le mensole si abbinano perfettamente alle basi porta lavabo con fianchi a terra.

The suspended columns and the shelves find their perfect combination with the furniture with washbasin and sides to the floor.

Die Hängesäule und die Fächer sich gut mit den Waschbeckenmöbeln kombiniert.

Les colonnes suspendues et les étagères trouvent leur meilleure combinaison avec les meubles avec lavabo et côtés par terre.





6

SYNTHESIS





6

SYNTHESIS



Specchi, pensili, complementi con ante o cassetti estraibili... Il tutto è pensato per dare la massima capienza all'insieme.

Mirrors, wall units and elements with doors and drawers... This line is studied to give the maximum capacity to the composition.

Spiegel, Hängeschränke, Möbel mit Türen oder Schubladen... Alles ist gedacht um die größte Fassungsvermögen zu geben.

Miroirs, armoires murales et complements avec portes ou tiroirs... Tout ça a été pensé pour donner capacité à l'ensemble de cette composition.





6

SYNTHESIS



SYNTHESIS VERSIONE SOSPESA.
SYNTHESIS SUSPENDED VERSION.
SYNTHESIS ZUM AUFHÄNGEN.
SYNTHESIS VERSION SUSPENDUE.

L'essenziale design del lavabo in perfetta simmetria con gli elementi a completamento, caratterizza la versione sospesa.

The essential design of the washbasin realized in perfect symmetry with the other elements of the collection can be found in the wall unit models.

Das wesentliche Design des Waschbeckens harmonisiert sich mit die Elementen der Hängeversion.

Le design essentiel du lavabo est en symétrie avec les éléments de cette collection qui caractérisent la version suspendue.





6

SYNTHESIS



Design dal tocco raffinato nella ricerca d'intimità tra le pareti del bagno.

Refined design to look for a real privacy in your bathroom.

Raffiniertes Design um Vertrautheit in Ihrem Badzimmer zu finden.

Design raffiné pour rechercher intimité dans Votre salle de bains.



6

SYNTHESIS



Elementi con cassetti su ruote per utilizzare con intelligenza il vostro spazio.

Elements with drawers and wheels studied to use with intelligence your space.

Möbel mit Rädern um mit Intelligenz Ihr Raum zu benutzen.

Éléments avec tiroirs et roues pour utiliser avec intelligence Votre espace.



6

SYNTHESIS



SYNTHESIS CON APPOGGIO SU PIEDINI.
SYNTHESIS WITH SUPPORT FEET.
SYNTHESIS MIT STÜTZFÜSSCHEN.
SYNTHESIS AVEC POSE SUR PIEDS.

Elementi con fianchi a terra, sospesi e d'appoggio su piedini consentono infinite soluzioni personalizzate.

Elements with sides to floor, suspended furniture and elements with feet give you the possibility to create your personal solution.

Die Elemente mit Seiten am Boden, die Hängeschränke und die Möbel mit Füßen erlauben unendliche Lösungen.

Éléments avec côtes par terre, suspendus et d'appui avec pieds Vous donnent solutions personnalisées et nouvelles.





6

SYNTHESIS





6

SYNTHESIS



Il raffinato accostamento di alluminio e vetro delle ante viene enfatizzato dagli effetti cromatici del piano.

The refined combination of aluminium and glass doors is set off by the chromatic effects of the surface.





Die raffinierte Annäherung zwischen Aluminium und Glas der Türen ist von den Farbwirkung der Platte betont.









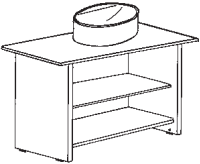
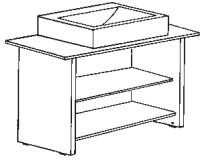
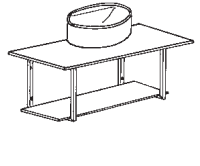
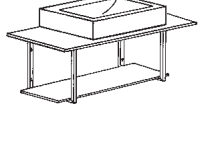



L'association raffinée du verre des portes et de l'aluminium est valorisée par les effets chromatique de la surface d'appui.















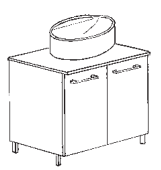

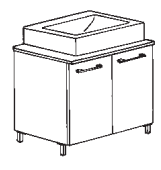
PIANO TOP TOP DESSUS	Piano di appoggio in cristallo sp. 15 mm. verniciato o in essenza di legno sp. 40 mm. Top made by 15-mm-varnished crystal or 40-mm-wood. Top aus gestrichenem Kristallglas mit 15 mm Tiefe oder Holz mit 40 mm Tiefe. La surface d'appui est en cristal épaisseur 15 mm verni ou sans bois épaisseur 40 mm.	faggio beech Buchenholz hêtre	acero maple Ahornholz érable	wengé wengé Wengé wengé	vetro glass Glas verre
STRUTTURA STRUCTURE STRUKTUR STRUCTURE	Struttura in nobilitato V100 spessore 18/28 mm. per i mobili lavabo e spessore 18 mm. per i relativi complementi. The structure is made by 18/28-mm-faced chipboard V100 for wash-basin furniture while the elements are made by 18-mm chipboard V100. Die Struktur des Waschbeckenmöbels ist aus melaminbeschichteten Spanplatte V100 mit 28 mm Stärke. Die Elemente sind aus wasserabstoßender melaminbeschichteten Spanplatte V100 mit 18 mm Stärke. La structure est en panneau de coupeaux épaisseur 18/28 mm pour le meuble lavabo et épaisseur 18 mm pour ses compléments.	bianco white Weiß blanc	faggio beech Buchenholz hêtre	wengé wengé Wengé wengé	acero maple Ahornholz érable
ANTA DOOR TÜR PORTE	L'anta è in truciolare sp. 18 mm. postformato e in vetro temperato da 4 mm. acidato su telaio in alluminio anodizzato. The door is made by 18-mm-postfomed chipboard. The glass door has profiles in anodized aluminium and a 4-mm-tempered glass. Die Tür ist aus vorgebildeter Spanplatte mit 18 mm Stärke. Die Glasür hat Profile aus eloxiertem Aluminium und ein Sicherheitglas mit 4 mm Stärke. La porte est en panneau de coupeaux épaisseur 18 mm arrondi et en verre trempé 4 mm acidifié avec un châssis en aluminium anodisé.	bianco white Weiß blanc	faggio beech Buchenholz hêtre	wengé wengé Wengé wengé	vetro glass Glas verre

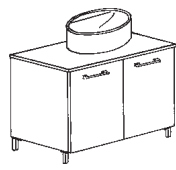
	Descrizione - Description Beschreibung - Description	Prof. D. - T. - P.	Largh. W. - B. - L.	Altezza H. - H. - H.				
	Mobile lavabo con piano in cristallo, lavabo diam. 43 cm. Wash-basin furniture with crystal top, basin with 43-cm diameter Waschbeckenmöbel mit Kristallplatte, Becken mit 43 cm Diameter Meuble lavabo avec appui en cristal, lavabo diamètre 43 cm.	51 cm	115 cm	83 cm	M.105.000			M.105.400
	Mobile lavabo con piano in cristallo, lavabo 60x50 cm. Wash-basin furniture with crystal top, basin 60x50 cm Waschbeckenmöbel mit Kristallplatte, Becken 60x50 cm Meuble lavabo avec appui en cristal, lavabo 60x50 cm.	51 cm	115 cm	85 cm	M.105.005			M.105.405
	Mobile lavabo su mensola con lavabo diam. 43 cm. Wash-basin furniture on shelf with 43-cm diameter-basin Möbel mit Fach und Becken mit 43 cm. Diameter Meuble lavabo sur une étagère avec lavabo diamètre 43 cm.	51 cm	115 cm	49 cm	M.105.011			M.105.010
	Mobile lavabo su mensola con lavabo 60x50 cm. Wash-basin furniture on shelf with wash basin cm. 60x50 Möbel mit Fach und Becken mit 60x50 cm. Meuble lavabo sur une étagère avec lavabo 60x50 cm.	51 cm	115 cm	51 cm	M.105.016			M.105.015

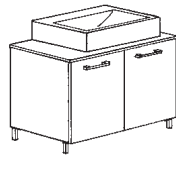
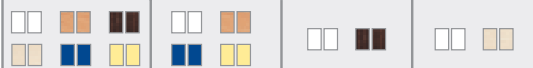
PIANO TOP TOP DESSUS	 vetro glass Glas verre						
STRUTTURA STRUCTURE STRUKTUR STRUCTURE	 bianco white Weiß blanc	 faggio beech Buchenholz hêtre	 wengé wengé Wengé wengé	 acero maple Ahornholz érable			
ANTA DOOR TÜR PORTE	 bianco white Weiß blanc	 faggio beech Buchenholz hêtre	 wengé wengé Wengé wengé	 acero maple Ahornholz érable	 blu blue Blau bleu	 giallo yellow Gelb jaune	 vetro glass Glas verre

	Descrizione - Description Beschreibung - Description	Prof. D. - T. - P.	Largh. W. - B. - L.	Altezza H. - H. - H.				
 <p>Mobile lavabo con piano in cristallo, lavabo diam. 43 cm. Wash-basin furniture with crystal top, basin with 43-cm diameter Waschbeckenmöbel mit Kristallplatte, Becken mit 43 cm Diameter Meuble lavabo avec appui en cristal, lavabo diamètre 43 cm.</p>	51 cm	70,5 cm	83 cm		M.105.020	M.105.420	M.105.421	
				M.105.025	M.105.425			
								
 <p>Mobile lavabo con piano in cristallo, lavabo 60x50 cm. Wash-basin furniture with crystal top, basin 60x50 cm Waschbeckenmöbel mit Kristallplatte, Becken 60x50 cm Meuble lavabo avec appui en cristal, lavabo 60x50 cm.</p>	51 cm	70,5 cm	85 cm		M.105.030	M.105.430	M.105.431	
				M.105.035	M.105.435			
								
 <p>Mobile lavabo con piano in cristallo, lavabo diam. 43 cm. Wash-basin furniture with crystal top, basin with 43-cm diameter Waschbeckenmöbel mit Kristallplatte, Becken mit 43 cm Diameter Meuble lavabo avec appui en cristal, lavabo diamètre 43 cm.</p>	51 cm	90,5 cm	83 cm		M.105.040	M.105.440	M.105.441	
				M.105.045	M.105.445			
								
 <p>Mobile lavabo con piano in cristallo, lavabo 60x50 cm. Wash-basin furniture with crystal top, basin 60x50 cm Waschbeckenmöbel mit Kristallplatte, Becken 60x50 cm Meuble lavabo avec appui en cristal, lavabo 60x50 cm.</p>	51 cm	90,5 cm	85 cm		M.105.050	M.105.450	M.105.451	
				M.105.055	M.105.455			
								

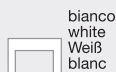
STRUTTURA
STRUCTURE
STRUKTUR
STRUCTURE

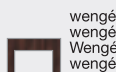
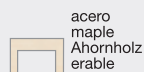
 bianco
white
Weiß
blanc

 faggio
beech
Buchenholz
hêtre

 wengé
wengé
Wengé
wengé

 acero
maple
Ahornholz
érable

ANTA
DOOR
TÜR
PORTE

 bianco
white
Weiß
blanc

 faggio
beech
Buchenholz
hêtre

 wengé
wengé
Wengé
wengé











 acero
maple
Ahornholz
érable















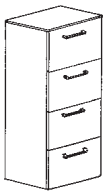















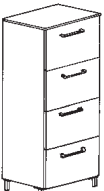











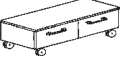

 blu
blue
Blau
bleu

 giallo
yellow
Gelb
jaune

 vetro
glass
Glas
verre

	Descrizione - Description Beschreibung - Description	Prof. D. - T. - P.	Largh. W. - B. - L.	Altezza H. - H. - H.	Cerniera Hinges Scharniere Ferroir				
	Base sospesa con piano in cristallo Hanging furniture with crystal top Hängegrundmöbel mit Kristallplatte Meuble suspendu avec appui en cristal	37,5 cm	35 cm	62 cm					
	Base con piano in cristallo Furniture with crystal top Möbel mit Kristallplatte Meuble avec appui en cristal	37,5 cm	35 cm	72 cm					
	Base sospesa 2 cassetti con piano in cristallo Hanging furniture with 2 drawers and crystal top Hängegrundmöbel mit 2 Schubladen und Kristallplatte Meuble suspendu avec deux tiroirs et appui en cristal	37,5 cm	35 cm	62 cm					
	Base 2 cassetti con piano in cristallo Furniture with 2 drawers and crystal top Möbel mit 2 Schubladen und Kristallplatte Meuble avec deux tiroirs et appui en cristal	37,5 cm	35 cm	72 cm					
			45 cm						

STRUTTURA STRUCTURE STRUKTUR STRUCTURE	 bianco white Weiß blanc	 faggio beech Buchenholz hêtre	 wengé wengé Wengé wengé	 acero maple Ahornholz érable			
ANTA DOOR TÜR PORTE	 bianco white Weiß blanc	 faggio beech Buchenholz hêtre	 wengé wengé Wengé wengé	 acero maple Ahornholz érable	 blu blue Blau bleu	 giallo yellow Gelb jaune	 vetro glass Glas verre

	Descrizione - Description Beschreibung - Description	Prof. D. - T. - P.	Largh. W. - B. - L.	Altezza H. - H. - H.	Cerniera Hinges Scharniere Fermoir				
	Base sospesa 4 cassetti con piano in cristallo Hanging furniture with 4 drawers and crystal top Hängegrundmöbel mit 4 Schubladen und Kristallplatte Meuble suspendu avec quatre tiroirs et appui en cristal	37,5 cm	35 cm	122 cm	-	  	 		
			45 cm			  	 	 	 
	Base 4 cassetti con piano in cristallo Furniture with 4 drawers and crystal top Möbel mit 4 Schubladen und Kristallplatte Meuble avec quatre tiroirs et appui en cristal	37,5 cm	35 cm	132 cm	-	  	 		
			45 cm			  	 	 	 
	Base a 2 cassetti con ruote e piano in cristallo Furniture on wheels with 2 drawers and crystal top Möbel mit Rädern, 2 Schubladen und Top aus Kristall Meuble à deux tiroirs avec roues et appui en cristal	37,5 cm	90 cm	32 cm	-				
						Base a 2 cassetti con ruote e piano in legno. Piano dello stesso colore della struttura. Furniture on wheels with 2 drawers and wooden top Top of the same colour of the structure Möbel mit Rädern, 2 Schubladen und Top aus Holz Top mit gesamter Farbe der Struktur Meuble à deux tiroirs avec roues et appui en bois. Appui de la même couleur de la structure.			

STRUTTURA
STRUCTURE
STRUKTUR
STRUCTURE



bianco
white
Weiß
blanc



faggio
beech
Buchenholz
hêtre



wengé
wengé
Wengé
wengé



acero
maple
Ahornholz
érable

ANTA
DOOR
TÜR
PORTE



bianco
white
Weiß
blanc



faggio
beech
Buchenholz
hêtre



wengé
wengé
Wengé
wengé



acero
maple
Ahornholz
érable

blu
blue
Blau
bleu

giallo
yellow
Gelb
jaune

vetro
glass
Glas
verre























	Descrizione - Description Beschreibung - Description	Prof. D. - T. - P.	Largh. W. - B. - L.	Altezza H. - H. - H.	Cerniera Hinges Scharniere Fermoir					
	Pensile Wall unit Hängeschränk Armoire murale	17 cm	25 cm	85 cm						
					dx - right rechts - droit sx - left links - gauche	M.105.200	M.105.700	M.105.702		
		dx - right rechts - droit sx - left links - gauche	M.105.210	M.105.710	M.105.712					
		dx - right rechts - droit sx - left links - gauche	M.105.211	M.105.711	M.105.713					
	Colonna sospesa Hängeschränk Colonne suspendue	25 cm	30 cm	180 cm						
					dx - right rechts - droit sx - left links - gauche	M.105.220	M.105.720	M.105.722		
		dx - right rechts - droit sx - left links - gauche	M.105.221	M.105.721	M.105.723					
		dx - right rechts - droit sx - left links - gauche	M.105.234 M.105.235		M.105.734 M.105.735					
	Colonna sospesa Hängeschränk Colonne suspendue	25 cm	45 cm	180 cm						
					dx - right rechts - droit sx - left links - gauche	M.105.240	M.105.740	M.105.742		
		dx - right rechts - droit sx - left links - gauche	M.105.241	M.105.741	M.105.743					
		dx - right rechts - droit sx - left links - gauche	M.105.254 M.105.255		M.105.754 M.105.755					
	Colonna sospesa Hängeschränk Colonne suspendue	25 cm	50 cm	144 cm						
					dx - right rechts - droit sx - left links - gauche	M.105.260	M.105.760	M.105.762		
					M.105.270		M.105.770			







STRUTTURA
STRUCTURE
STRUKTUR
STRUCTURE

bianco white Weiß blanc
faggio beech Buchenholz hêtre
wengé wengé Wengé wengé
acero maple Ahornholz érable

ANTA
DOOR
TÜR
PORTE

bianco white Weiß blanc
faggio beech Buchenholz hêtre
wengé wengé Wengé wengé
acero maple Ahornholz érable
blu blue Blau bleu
giallo yellow Gelb jaune
vetro glass Glas verre

	Descrizione - Description Beschreibung - Description	Prof. D. - T. - P.	Largh. W. - B. - L.	Altezza H. - H. - H.	Cerniera Hinges Scharniere Fermeoir				
	Colonna Column Hangesäule Colonne	25 cm	30 cm	180 cm					
					dx - right rechts - droit sx - left links - gauche	M.105.320	M.105.820	M.105.822	
									
					dx - right rechts - droit sx - left links - gauche	M.105.334 M.105.335	M.105.834 M.105.835		
	Colonna Column Hangesäule Colonne	25 cm	45 cm	180 cm					
					dx - right rechts - droit sx - left links - gauche	M.105.340 M.105.341	M.105.840 M.105.841	M.105.842 M.105.843	
									
					dx - right rechts - droit sx - left links - gauche	M.105.354 M.105.355	M.105.854 M.105.855		

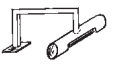
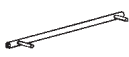
	Descrizione - Description Beschreibung - Description	Prof. D. - T. - P.	Largh. W. - B. - L.	Altezza H. - H. - H.				
	Mensole in legno Wooden shelf Holzfach Etagères en bois	15 cm	30 cm		M.398.021.001	M.398.021.002	M.398.021.003	M.398.021.004
			45 cm	4 cm	M.398.021.011	M.398.021.012	M.398.021.013	M.398.021.014
			100 cm		M.398.021.021	M.398.021.022	M.398.021.023	M.398.021.024
	Mensole in cristallo Crystal shelf Kristallfach Etagères en cristal	30 cm		M.398.022.001				
		45 cm	1 cm	M.398.022.002				
		100 cm		M.398.022.003				
	Specchiera Mirror Spiegel Miroir	3 cm	45 cm	100 cm	M.399.002.100			
			100 cm	45 cm	M.399.002.101			
	Lampada Lamp Lampe Lampe	-	22 cm	-	M.399.591.005			
	Porta salviette solo per mobile lavabo cod. 105.000-105.005-105.400-105.405 Towel rack only for washbasin furniture cod. 105.000-105.005-105.400-105.405 Handtuchhalter nur für Waschbeckenmöbel Kod. 105.000-105.005-105.400-105.405 Porte-serviettes pour meuble lavabo cod. 105.000-105.005-105.400-105.405	-	40 cm	-	M.399.580.005			

Sinergy è l'idea che abbina in un'unica soluzione le linee di un bagno moderno alla praticità di un lavatoio. Una leggera pressione e il piano si solleva trasformandosi in asse per lavare e sotto si cela una capiente vasca lavatoio perfettamente integrata nell'armonia delle forme.

Sinergy is the new idea of Montegrappa which combines in a sole solution the lines of a modern bathroom and the practicalness of a washing trough. A light pressure and the top rises becoming a scrubbing board and underneath there is a capacious basin which is perfectly integrated in the harmony of the shapes.

Sinergy ist die neue Idee von Montegrappa und sie kombiniert die Linien einem modernen Badzimmer mit der Zweckmäßigkeit einem Waschtrogmöbel in einer einzigen Lösung. Ein leichter Druck und die Platte richtet sich auf und verwandelt sich in ein Waschbrett. Unter der Platte gibt es ein geräumiges Waschbecken, das völlig mit der Harmonie der Formen integriert ist.

Sinergy est l'idée qui met ensemble les lignes de la salle de bains moderne et la praticité du lavoir. Avec une légère pression de la main le dessus devient une planche à laver. Au-dessus le bac-lavoir en ligne avec l'harmonie des formes.



Colori disponibili per il piano
Available colours for the top
Verfügbare Farbvarianten für den Waschtisch
Couleurs disponibles pour le plan

bianco
white
Weiß
blanc 

Colori disponibili per la struttura
Available colours for the structure
Verfügbare Farben für die Struktur
Couleurs disponibles pour la structure

bianco
white
Weiß
blanc 

faggio
beech
Buchenholz
hêtre 

wengé
wengé
Wengé
wengé 

acero
maple
Ahornholz
érable 

Colori disponibili per le ante
Available colours for the doors
Verfügbare Farben für die Türen
Couleurs disponibles pour les portes

bianco
white
Weiß
blanc 

faggio
beech
Buchenholz
hêtre 

wengé
wengé
Wengé
wengé 

acero
maple
Ahornholz
érable 

blu
blue
Blau
bleu 

giallo
yellow
Gelb
jaune 

vetro
glass
Glas
verre 



7

SINERGY





7

SINERGY

Sobrie ed eleganti soluzioni come colonne e pensili completano Sinergy soddisfacendo qualsiasi vostra necessità.

Simple and elegant solutions such as wall units and mirrors complete Sinergy satisfying all your needs.

Einfache und elegante Lösungen wie Hängeschränke und Spiegel ergänzen Sinergy und befriedigen Ihre Bedürfnisse.

Colonnes, armoires murales et miroirs sont les compléments de Sinergy . Solutions élégantes pour satisfaire à toutes Vos exigences.





7

SINERGY

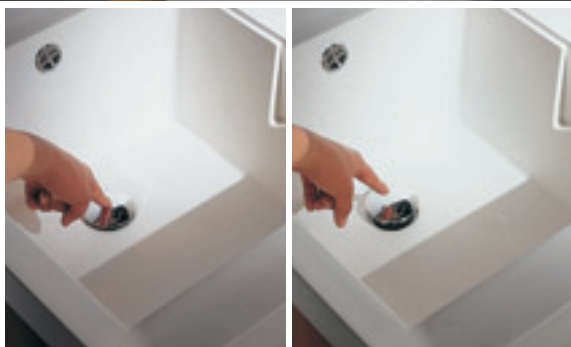

Una piletta innovativa, un pratico cesto portabiancheria sono alcuni degli accessori che arricchiscono Sinergy.

An innovative drain and a practical laundry basket are some of the accessories which enrich Sinergy.

Ein innovativer Abfluss und ein praktischer Waschkorb sind manche der Zubehören, die Sinergy bereichern.

L'innovateur branchement hydrique et le pratique panier à linges sont seulement quelques-uns des accessoires pour completer Sinergy.



7

SINERGY



Un solo gesto, una leggera rotazione del mixer a 180° e dal bagno ci si trasferisce in lavanderia.

A sole move and a light rotation of the tap of 180 degrees and from the bathroom we find ourselves in the wash-house.



Eine einzige Geste und eine leichte Rotation der Armatur von 180 Grad und vom Badzimmer finden wir uns in der Waschküche.

Une légère rotation du robinet mitigeur pour 180° et de la salle de bains on est dans Votre buanderie.



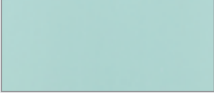
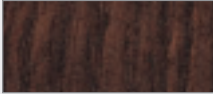
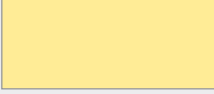
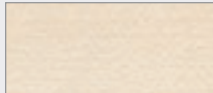

TABELLA COLORE
COLOURS
FARBEN
TABLEAU DES COULEURS

COLORI DISPONIBILI AVAILABLE COLOURS VERFÜGBARE FARBEN COULEURS DISPONIBLES				
	bianco white Weiß blanc	faggio beech Buchenholz hêtre	blu blue Blau bleu	vetro glass Glas verre
				
		wengé wengé Wengé wengé	giallo yellow Gelb jaune	
				
	acero maple Ahornholz érable			

COMBINAZIONI DISPONIBILI
AVAILABLE COMBINATIONS
VERFÜGBARE KOMBINATIONEN
COMBINATIONS DISPONIBLES

STRUTTURA STRUCTURE STRUKTUR STRUCTURE				
FRONTALI FRONT PARTS FRONTSEITEN FACADE ante/cassetti doors/drawers Türen/Schubladen Portes/tiroirs	     	   	 	 
solo ante only doors nur Türen seulement portes				

GUIDA ALLA SCELTA DEGLI ELEMENTI
GUIDE TO ELEMENTS CHOICE
LEITFADEN ZUR WAHL DER ELEMENTEN
GUIDE AU CHOIX DES ELEMENTS

Mobile lavabo/lavatoio Washbasin/trough furniture Waschbecken –und Trogmöbel Meuble lavabo-lavoir	con piedini o sospeso, con ante o anta e cassetti with feet or hanging, with doors or one door and drawers mit Füßen oder aufgehängt, mit Türen oder ein Tür und Schubladen avec pieds ou suspendu, avec porte ou portes et tiroirs	pag 72-73
Basi Basic furniture Grundmöbel Meuble	con piedini o sospese, con ante o anta e cassetti with feet or hanging, with doors or one door and drawers mit Füßen oder aufgehängt, mit Türen oder ein Tür und Schubladen avec pieds ou suspendues, avec porte ou portes et tiroirs	pag 74-75
Pensili Wall units Hängeschränke Armoires murales	con anta with doors mit Tür avec porte	pag 75
Colonne Columns Säule Colonne	con piedini o sospese, con anta singola o doppia with feet or hanging, with one or two doors mit Füßen oder aufgehängt, mit ein oder zwei Türen avec pieds ou suspendues, avec une ou deux portes	pag 76-77
Accessori Accessoires Zubehöre Accessoires		pag 77

CARATTERISTICHE TECNICHE
TECHNICAL DETAILS
TECHNISCHE DATEN
CARACTERISTIQUES TECHNIQUES

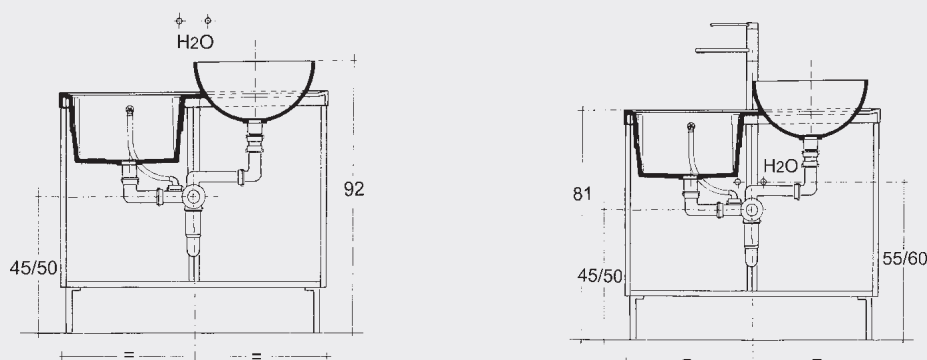





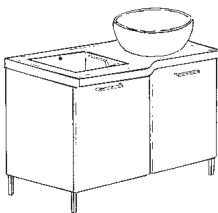
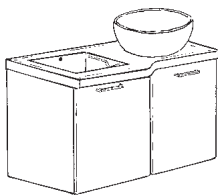
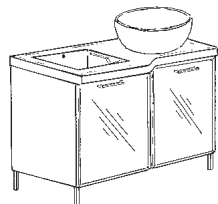
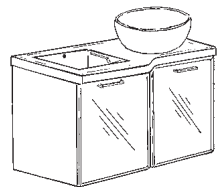

Posizionamento scarico e attacchi idrici.
 Positioning of the drainage and the water bindings.
 Positionierung dem Abfluss und der Wasserverbindung.
 Position des vidages et branchement hydrique.

Mobile completo di sifone e piletta.
 Furniture equipped with drain and siphon.
 Möbel mit Abflüsse und Siphon.
 Meuble avec vidange et branchement hydrique.

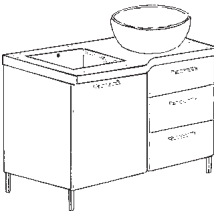
PIANO TOP TOP DESSUS	Piano di appoggio in materiale sintetico colore bianco, in cristallo verniciato per complementi. Top in white synthetic material, elements in lacquered glass. Fläche aus KUNSTSTOFF, weiss, Elemente aus lackiertem Kristallglas. Surface d'appui en matériau synthétique, couleur blanc, en cristal verni pour les compléments.								bianco white Weiß blanc						
STRUTTURA STRUCTURE STRUKTUR STRUCTURE	Struttura in nobilitato V100 spessore 18mm. The structure is made by 18mm faced chipboard V100. Die Struktur des Waschbeckenmöbels ist aus melaminbeschichteten Spanplatte V100 mit 18mm Stärke. La structure est en panneau de coupeaux et papier V100 épaisseur 18mm.								bianco white Weiß blanc	faggio beech Buchenholz hêtre	wengé wengé Wengé wengé	acero maple Ahornholz érable			
ANTA DOOR TÜR PORTE	L'anta è in truciolare sp. 18mm postformato e in vetro temperato da 4 mm acidato su telaio in alluminio anodizzato. The door is made by 18mm postformed chipboard. The glass door has profiles in anodized aluminium and a 4mm tempered glass. Die Tür ist aus vorgebildeter Spanplatte mit 18 mm Stärke. Die Glastür hat Profile aus eloxiertem Aluminium und ein Sekuritglas mit 4mm Stärke. La porte est en panneau de coupeaux épaisseur 18mm arrondi et en verre trempé 4mm acidifié avec un châssis en aluminium anodisé.								bianco white Weiß blanc	faggio beech Buchenholz hêtre	wengé wengé Wengé wengé	acero maple Ahornholz érable	blu blue Blau bleu	giallo yellow Gelb jaune	vetro glass Glas verre

	Descrizione - Description Beschreibung - Description	Prof. D. - T. - P.	Largh. W. - B. - L.	Altezza H. - H. - H.				
	Mobile lavabo-lavatoio con piedini ante legno Washbasin/trough furniture with feet with wooden doors Waschbecken-und Trogmöbel mit Füßen Holztüren Meuble lavabo-lavoir avec pieds portes en bois	50-52 cm	91 cm	81-92 cm				
	Con cesto With Laundry basket Mit Wäschekorb Avec Panier							
	Mobile lavabo-lavatoio sospeso ante legno Hanging washbasin/trough furniture with wooden doors Hängewaschbecken-und Trogmöbel mit Holztüren Meuble lavabo-lavoir suspendu portes en bois	50-52 cm	91 cm	66-77 cm				
	Con cesto With Laundry basket Mit Wäschekorb Avec Panier							
	Mobile lavabo-lavatoio con piedini ante vetro Washbasin/trough furniture with feet with glass doors Waschbecken-und Trogmöbel mit Füßen mit Glastüren Meuble lavabo-lavoir avec pieds Portes en verre	50-52 cm	91 cm	81-92 cm				
	Con cesto With Laundry basket Mit Wäschekorb Avec Panier							
	Mobile lavabo-lavatoio sospeso ante vetro Hanging Washbasin/trough furniture with glass doors Hängewaschbecken-und Trogmöbel mit Glastüren Meuble lavabo-lavoir suspendu Portes en verre	50-52 cm	91 cm	66-77 cm				
	Con cesto With Laundry basket Mit Wäschekorb Avec Panier							

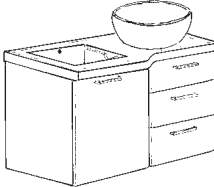
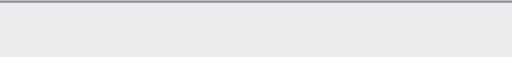
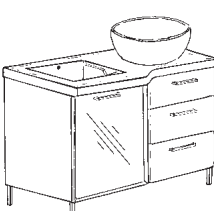

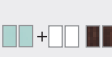
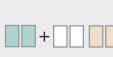
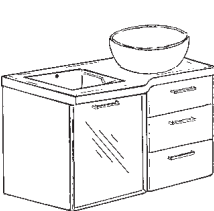
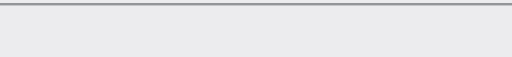







PIANO TOP TOP DESSUS	bianco white Weiß blanc						
STRUTTURA STRUCTURE STRUKTUR STRUCTURE	bianco white Weiß blanc	faggio beech Buchenholz hêtre	wengé wengé Wengé wengé	acero maple Ahornholz érable			
ANTA DOOR TÜR PORTE	bianco white Weiß blanc	faggio beech Buchenholz hêtre	wengé wengé Wengé wengé	acero maple Ahornholz érable	blu blue Blau bleu	giallo yellow Gelb jaune	vetro glass Glas verre















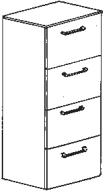









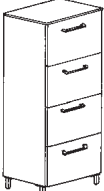











	Descrizione - Description Beschreibung - Description	Prof. D. - T. - P.	Largh. W. - B. - L.	Altezza H. - H. - H.				
	Mobilia lavabo-lavatoio con piedini anta legno, vano ripostiglio e due cassetti Washbasin/trough furniture with feet with wooden door and two drawers Waschbecken- und Trogmöbel mit Füßen mit Holztor und zwei Schubladen Meuble lavabo-lavoir avec pieds Porte en bois, embrasure et deux tiroirs	50-52 cm	91 cm	81-92 cm				
	Con cesto With Laundry basket Mit Wäschekorb Avec Panier				M.107.011	M.107.015		
	Mobilia lavabo-lavatoio sospeso anta legno, vano ripostiglio e due cassetti Hanging washbasin/trough furniture with wooden door and two drawers Hängewaschbecken- und Trogmöbel mit Holztor und zwei Schubladen Meuble lavabo-lavoir suspendu Porte en bois, embrasure et deux tiroirs	50-52 cm	91 cm	66-77 cm				
	Con cesto With Laundry basket Mit Wäschekorb Avec Panier				M.107.012	M.107.016		
	Mobilia lavabo-lavatoio con piedini anta vetro, vano ripostiglio e due cassetti Washbasin/trough furniture with feet with glass door and two drawers Waschbecken- und Trogmöbel mit Füßen mit Glastor und zwei Schubladen Meuble lavabo-lavoir avec pieds Porte en verre, embrasure et deux tiroirs	50-52 cm	91 cm	81-92 cm				
	Con cesto With Laundry basket Mit Wäschekorb Avec Panier				M.107.041	M.107.045		
	Mobilia lavabo-lavatoio sospeso anta vetro, vano ripostiglio e due cassetti Hanging washbasin/trough furniture with glass door and two drawers Hängewaschbecken- und Trogmöbel mit Füßen mit Glastor und zwei Schubladen Meuble lavabo-lavoir suspendu Porte en bois, embrasure et deux tiroirs	50-52 cm	91 cm	66-77 cm				
	Con cesto With Laundry basket Mit Wäschekorb Avec Panier				M.107.042	M.107.046		

STRUTTURA
STRUCTURE
STRUKTUR
STRUCTURE

ANTA
DOOR
TÜR
PORTE

	Descrizione - Description Beschreibung - Description	Prof. D. - T. - P.	Largh. W. - B. - L.	Altezza H. - H. - H.	Cerniera Hinges Scharniere Fermoir				
	Base sospesa con piano in cristallo Hanging furniture with crystal top Hängegrundmöbel mit Kristallplatte Meuble suspendu avec appui en cristal	37,5 cm	35 cm	62 cm					
						dx - right rechts - droit sx - left links - gauche	M.107.100 M.107.101	M.107.500 M.107.501	M.107.502 M.107.503
						dx - right rechts - droit sx - left links - gauche	M.107.104 M.107.105	M.107.504 M.107.505	M.107.506 M.107.507
						dx - right rechts - droit sx - left links - gauche	M.107.110 M.107.111		M.107.510 M.107.511
						dx - right rechts - droit sx - left links - gauche	M.107.114 M.107.115		M.107.514 M.107.515
	Base con piano in cristallo Furniture with crystal top Möbel mit Kristallplatte Meuble avec appui en cristal	37,5 cm	35 cm	77 cm					
						dx - right rechts - droit sx - left links - gauche	M.107.120 M.107.121	M.107.520 M.107.521	M.107.522 M.107.523
						dx - right rechts - droit sx - left links - gauche	M.107.124 M.107.125	M.107.524 M.107.525	M.107.526 M.107.527
						dx - right rechts - droit sx - left links - gauche	M.107.130 M.107.131		M.107.530 M.107.531
						dx - right rechts - droit sx - left links - gauche	M.107.134 M.107.135		M.107.534 M.107.535
	Base sospesa 2 cassetti con piano in cristallo Hanging furniture with 2 drawers and crystal top Hängegrundmöbel mit 2 Schubladen und Kristallplatte Meuble suspendu avec deux tiroirs et appui en cristal	37,5 cm	35 cm	62 cm	-				
			45 cm			M.107.140	M.107.540	M.107.542	
	Base 2 cassetti con piano in cristallo Furniture with 2 drawers and crystal top Möbel mit 2 Schubladen und Kristallplatte Meuble avec deux tiroirs et appui en cristal	37,5 cm	35 cm	77 cm	-				
			45 cm			M.107.150	M.107.550	M.107.552	
						M.107.154	M.107.554	M.107.556	

STRUTTURA STRUCTURE STRUKTUR STRUCTURE	 bianco white Weiß blanc	 faggio beech Buchenholz hêtre	 wengé wengé Wengé wengé	 acero maple Ahornholz érable			
ANTA DOOR TÜR PORTE	 bianco white Weiß blanc	 faggio beech Buchenholz hêtre	 wengé wengé Wengé wengé	 acero maple Ahornholz érable	 blu blue Blau bleu	 giallo yellow Gelb jaune	 vetro glass Glas verre

	Descrizione - Description Beschreibung - Description	Prof. D. - T. - P.	Largh. W. - B. - L.	Altezza H. - H. - H.	Cerniera Hinges Scharniere Fermoir				
	Base sospesa 4 cassetti con piano in cristallo Hanging furniture with 4 drawers and crystal top Hängegrundmöbel mit 4 Schubladen und Kristallplatte Meuble suspendu avec quatre tiroirs et appui en cristal	37,5 cm	35 cm	122 cm	-	   	 	 	 
			45 cm			M.107.160	M.107.560	M.107.562	
	Base 4 cassetti con piano in cristallo Furniture with 4 drawers and crystal top Möbel mit 4 Schubladen und Kristallplatte Meuble avec quatre tiroirs et appui en cristal	37,5 cm	35 cm	137 cm	-	   	 	 	 
			45 cm			M.107.170	M.107.570	M.107.572	
	Pensile Wall unit Hängeschränk Armoire murale	17 cm	25 cm	85 cm	dx - right rechts - droit sx - left links - gauche	   	 	 	 
						M.107.200	M.107.700	M.107.702	
						M.107.201	M.107.701	M.107.703	
						M.107.210	M.107.710	M.107.712	
						M.107.211	M.107.711	M.107.713	
									
M.107.204	M.107.704	M.107.704							
M.107.205	M.107.705	M.107.705							
M.107.214	M.107.714	M.107.714							
M.107.215	M.107.715	M.107.715							

STRUTTURA
STRUCTURE
STRUKTUR
STRUCTURE

 bianco
white
Weiß
blanc

 faggio
beech
Buchenholz
hêtre

 wengé
wengé
Wengé
wengé

 acero
maple
Ahornholz
érable

ANTA
DOOR
TÜR
PORTE

 bianco
white
Weiß
blanc

 faggio
beech
Buchenholz
hêtre

 wengé
wengé
Wengé
wengé











 acero
maple
Ahornholz
érable















 blu
blue
Blau
bleu









 giallo
yellow
Gelb
jaune

 vetro
glass
Glas
verre

	Descrizione - Description Beschreibung - Description	Prof. D. - T. - P.	Largh. W. - B. - L.	Altezza H. - H. - H.	Cerniera Hinges Scharniere Fermoir				
	Colonna sospesa Hanging column Hangesäule Colonne suspendue	25 cm	30 cm	180 cm					
					dx - right rechts - droit sx - left links - gauche	M.107.220	M.107.720	M.107.722	
						M.107.221	M.107.721	M.107.723	
						M.107.234	M.107.734		
						M.107.235	M.107.735		
	Colonna sospesa Hanging column Hangesäule Colonne suspendue	25 cm	45 cm	180 cm					
					dx - right rechts - droit sx - left links - gauche	M.107.240	M.107.740	M.107.742	
						M.107.241	M.107.741	M.107.743	
						M.107.254	M.107.754		
						M.107.255	M.107.755		
	Colonna sospesa Hanging column Hangesäule Colonne suspendue	25 cm	50 cm	144 cm					
						M.107.260	M.107.760	M.107.762	
						M.107.270	M.107.770		
	Colonna Column Hangesäule Colonne	25 cm	30 cm	195 cm					
					dx - right rechts - droit sx - left links - gauche	M.107.320	M.107.820	M.107.822	
						M.107.321	M.107.821	M.107.823	
						M.107.334	M.107.834		
						M.107.335	M.107.835		

STRUTTURA STRUCTURE STRUKTUR STRUCTURE	 bianco white Weiß blanc	 faggio beech Buchenholz hêtre	 wengé wengé Wengé wengé	 acero maple Ahornholz érable			
ANTA DOOR TÜR PORTE	 bianco white Weiß blanc	 faggio beech Buchenholz hêtre	 wengé wengé Wengé wengé	 acero maple Ahornholz érable	 blu blue Blau bleu	 giallo yellow Gelb jaune	 vetro glass Glas verre

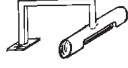
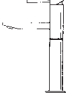
	Descrizione - Description Beschreibung - Description	Prof. D. - T. - P.	Largh. W. - B. - L.	Altezza H. - H. - H.	Cerniera Hinges Scharniere Ferroir				
	Colonna Column Hangesäule Colonne	25 cm	45 cm	195 cm		  	 	 	 
					dx - right rechts - droit sx - left links - gauche	M.107.340	M.107.840	M.107.842	
						M.107.341	M.107.841	M.107.843	
									
	dx - right rechts - droit sx - left links - gauche	M.107.354	M.107.854	M.107.855					
		M.107.355	M.107.855						

	Descrizione - Description Beschreibung - Description	Prof. D. - T. - P.	Largh. W. - B. - L.	Altezza H. - H. - H.				
	Mensole in legno Wooden shelves Holzfächer Etagères en bois	15 cm	30 cm		M.398.021.001	M.398.021.002	M.398.021.003	M.398.021.004
			45 cm	4 cm	M.398.021.011	M.398.021.012	M.398.021.013	M.398.021.014
			100 cm		M.398.021.021	M.398.021.022	M.398.021.023	M.398.021.024
	Mensole in cristallo Crystal shelves Kristallfächer Etagères en cristal	30 cm		M.398.022.001				
		45 cm	1 cm	M.398.022.002				
		100 cm		M.398.022.003				
	Specchiera Mirror Spiegel Miroir	3 cm	45 cm	100 cm	M.399.002.100			
			100 cm	45 cm	M.399.002.101			
	Lampada Lamp Lampe Lampe	-	22 cm	-	M.399.591.005			
	Rubinetto monocomando per lavabo Single-lever tap for washbasin Einhebelarmatur für Waschbecken Robinet mitigeur pour lavabo	-	-	-	"Comfort" M.399.404.100			
					"Design" M.399.404.101			

Arredamenti Montegrappa si riserva tutti i diritti sui modelli illustrati che sono di sua esclusiva proprietà, come pure il catalogo messo a disposizione della Clientela. Le illustrazioni, i colori e le descrizioni non vincolano eventuali variazioni di produzione.

Arredamenti Montegrappa reserves all rights on the illustrated models, which are of his own property, as well as the catalogue for the customers.

Arredamenti Montegrappa behält alle Rechte über die illustrierte Modelle vor, sowie über den Katalog für die Kunden. Die Bebilderungen, die Farben und die Beschreibungen binden keine potentielle Produktionsveränderungen.

La société Arredamenti Montegrappa se réserve tous les droits sur les modèles illustrés qui sont sa propriété exclusive, de même que le catalogue mis à la disposition de la Clientèle. Les illustrations, les couleurs et les descriptions n'interdisent pas d'éventuelles variations de production.





Montegrappa®

ARREDAMENTI
MONTECRAPPA
S.P.A.

Arredamenti Montegrappa Spa
Via Spin, 124 - 36060 Romano d'Ezzelino (VI) Italy
Tel. 0424.37405 - Fax 0424.37420
www.montegrappa.it
info@montegrappa.it

